

Order number: 189951

**Technical data:**

Lamp wattage (nominal value):	100 W
Lamp voltage:	12 V
Beam angle:	36°
Luminous intensity:	3700 cd
Colour temperature:	3100 K
Chromaticity coordinate x:	0.43
Chromaticity coordinate y:	0.4
Colour rendering:	100
Average life (nominal value):	3500 h
Diameter:	50,7mm max.
Length L:	45,2 mm
Reflectorcolor:	clear
Reflectorcoating:	dichroic
Filament:	c-8
Base:	GU5.3
Reliable burning position:	u360
Packing unit (pcs.):	50
For open fixtures:	Yes
Closed:	Yes
Dimmable:	Yes
UV-P:	Yes
ILCOS:	HRGS/C-100-12-GU5.3-51/36



**Advantages:**

- High-quality titanium oxide coating
- Constant light colours through the rear of the reflectors
- Exact illumination through precise beam angle
- UV protection (UV-P)
- Dimmable

**Application:**

- Application for accent illumination where large quantities of lamps are required, e.g.:
- Hotels
  - Restaurants
  - Fairs and exhibitions
  - Shops
  - Open-plan offices

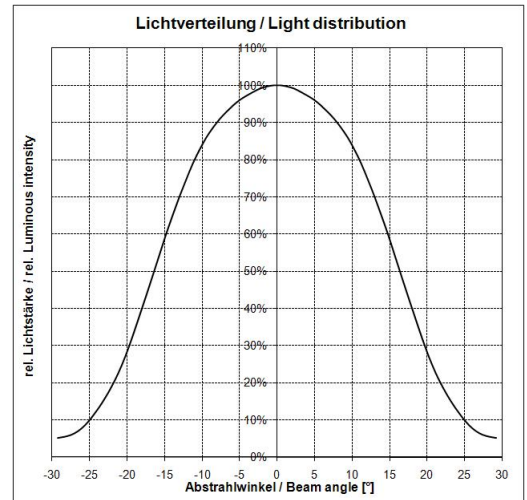
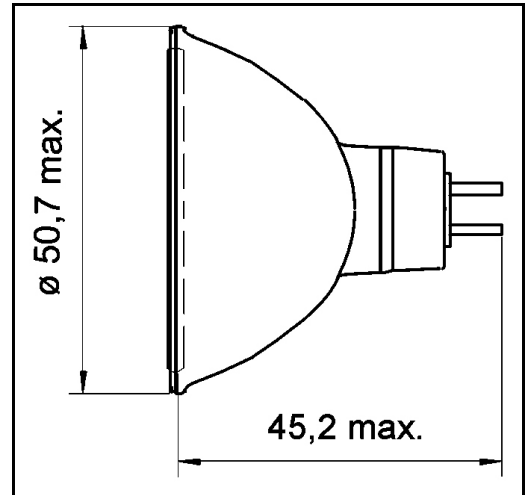

Ø [m]	H [m]	E [lx]
0,65	1	3700
1,30	2	925
1,95	3	411
2,60	4	231

Within the scope of the corresponding standards, variations of the declared values and tolerances might occur without prior notice.